

INSTALLATION INSTRUCTIONS

DESCRIPTION: Light Bar Kit
 PART NUMBER: 2HC-H4104-XX
 MODEL: YXZ1000R



WARNING

Please read and understand these instructions completely before installation to avoid possible injury, or damage to the accessory or vehicle.

NOTICES:

This installation requires a torque wrench and should be performed by an authorized Yamaha dealer or other qualified technician.

WARRANTY INFORMATION:

Genuine Yamaha Accessories are covered by a one-year limited warranty against defects in material or workmanship. Labor for replacement of defective components is not covered. See your Yamaha dealer for a copy of the warranty statement.

DEALER OR INSTALLER:

These instructions contain important information for future reference and *must* be given to the customer.

The following Light Bar Kits are designed to be used in conjunction with the Yamaha Alternator Kit (p/n 2HC-H1200-V0):

- 16 LED HALO (p/n 2HC-H4104-T0), 8 LED HALO (p/n 2HC-H4104-P0) and 16 LED Radiant (p/n 2HC-H4104-R0)

PARTS LIST:

No.	Part Number	Description	Qty
--	2HC-H4104-XX	Light Bar Kit	--
①	*	Upper Bracket	2
②	*	Under Bracket	2
③	*	Mount Base	2
④	*	M6 x 20mm Button Head Bolt	2
⑤	*	M6 x 16mm Button Head Bolt	8
⑥	*	T Bolt 75mm	2
⑦	*	Collar	2
⑧	*	M6 Nylock Nut	2
⑨	*	M6 Washer	2
⑩	*	Light Bar (14" or 27" – various types)	1
⑪	*	Wiring Harness (sized to Fit Light Bar)	1

* Part supplied with kit only and not available separately.

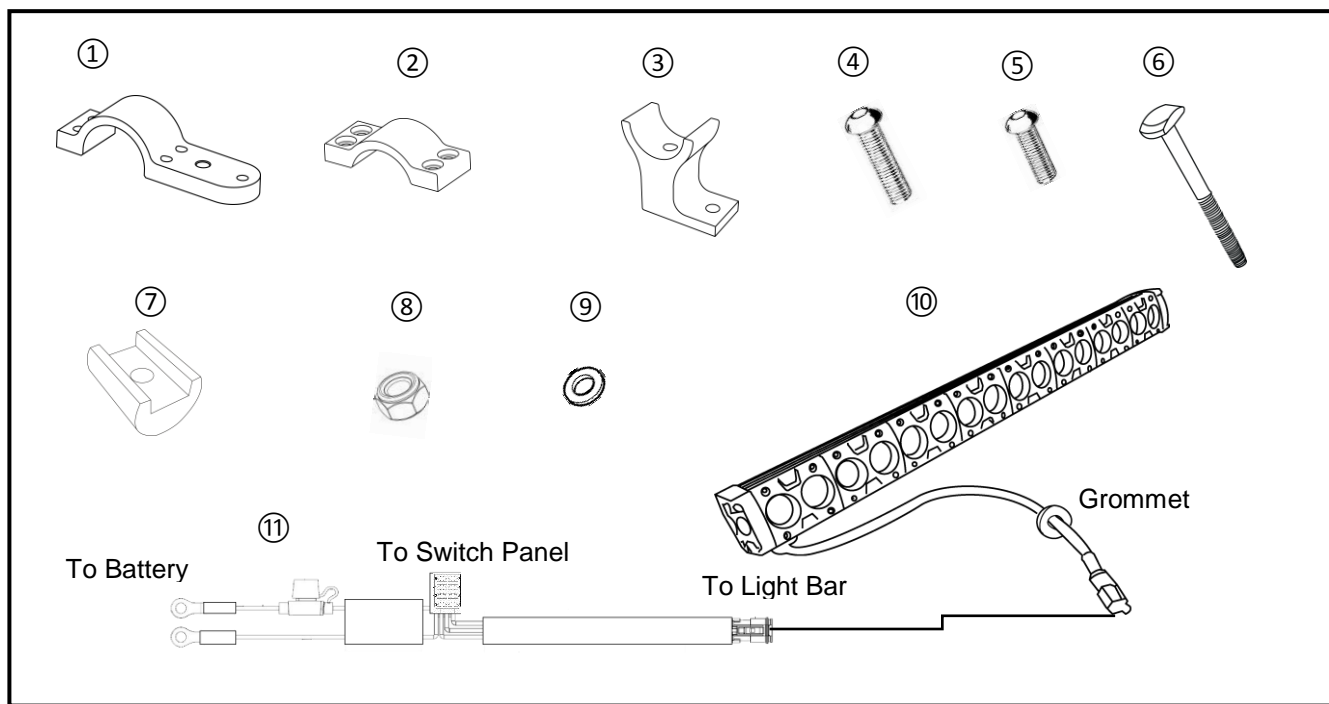

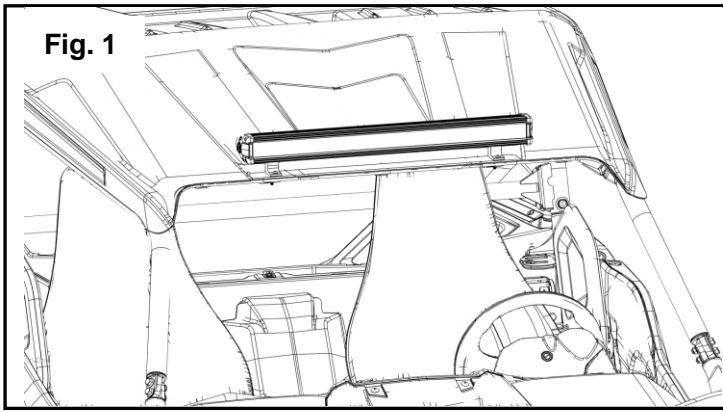
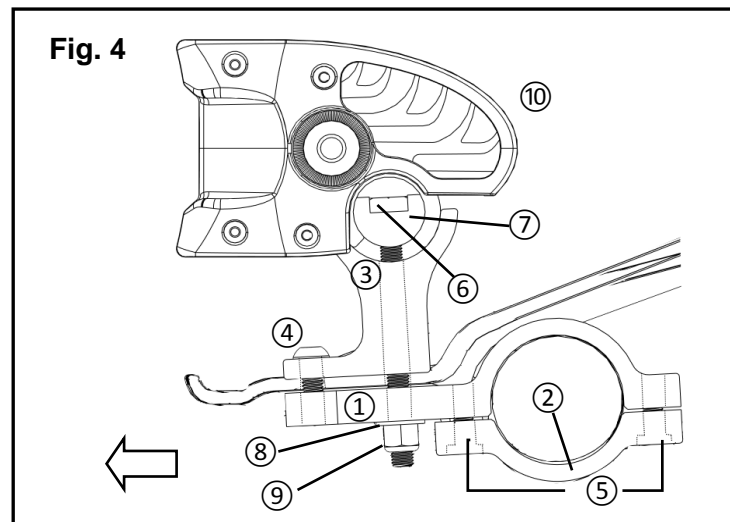
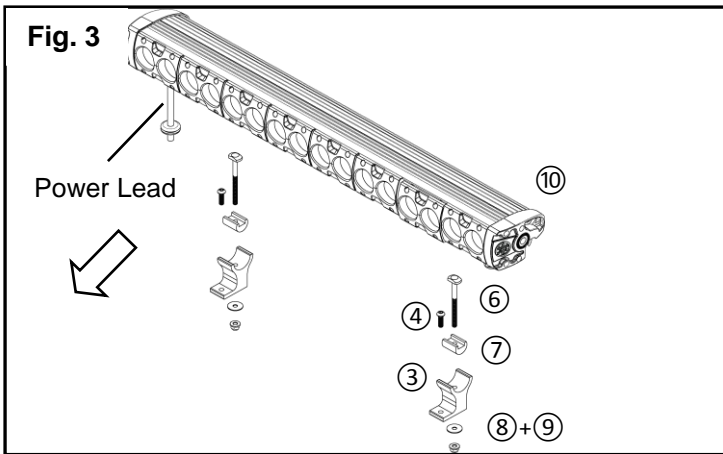
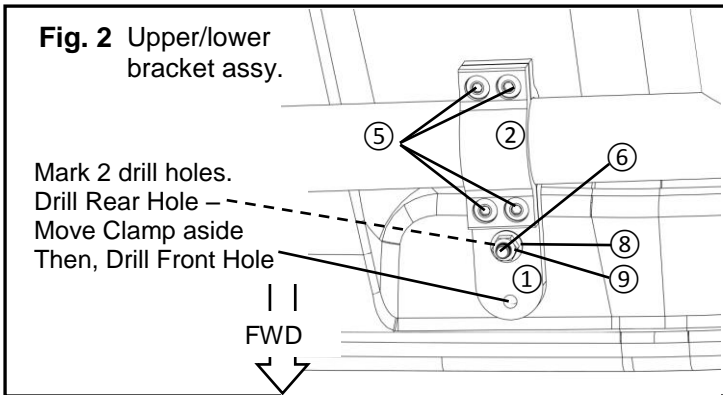

Fig. 1



PREPARATION:

- Park the vehicle on a secure and level surface.
- Clean all mounting surfaces before beginning installation.

INSTALLATION:

Install the Light Bar to the Roof

1. Working from inside the vehicle, remove the stock bolts and clamps that hold the leading edge of the roof to the overhead bars. Retain the 6 bolts and 3 clamps for reuse.
2. On the left side of the cab, slip an Upper Bracket (1) between the roof and the overhead bar so that it wraps around the overhead bar. Position the Under Bracket (2) so that it wraps around the overhead bar from underneath. Pass 4 M6x16mm button head bolts (5) through the under bracket (2) and thread into the Upper Bracket (1) (Fig. 2) - leave these bolts loose.
3. Repeat step 2 on the right side of the cab. For 8 LED light bars it is recommended to space the brackets approximately 215mm apart, measuring from the center of both brackets. For 16 LED light bars, space the brackets approximately 560mm apart.
4. Install the stock clamps and bolts removed in step 1 back in place to secure the roof to the overhead bars.
5. Working from the left side of the cab, press the upper bracket (1) up so that the long arm of the bracket is flush with the roof (Fig. 4).
6. Tighten 4 M6x16mm button head bolts (5) that attach the lower bracket (2) to the upper bracket (1) (Fig. 2).
7. Repeat steps 5 and 6 on the right side.
8. Use the holes in the upper bracket (1) as guides to mark the locations of drill holes. There will be 2 marks for each side (4 total).
9. Working from inside the cab, Use a 1/4" drill bit, and drill out only the 2 rear most holes (1 on each side). We are using the bracket as a drill guide for this operation.
Note: The forward hole in the upper bracket is threaded. We do not want to damage those threads by drilling through the upper bracket.
10. On the left side, loosen the 4 M6 x 16mm button head bolts (6) and slide the upper/lower bracket assembly out of the way. Use a 5/16" drill bit to drill out the hole you marked, but did not drill, in step 8.
11. Repeat steps 10 on the right side. Then, slide the upper/lower bracket assembly back into place so that the holes in the roof align with the holes in the upper/lower bracket assembly.
12. Tighten the M6 x 16mm bolts (5) holding the upper and lower brackets together on both the left and right side, but do not torque them yet.
13. Position the 2 Mount Bases (3) over the drilled

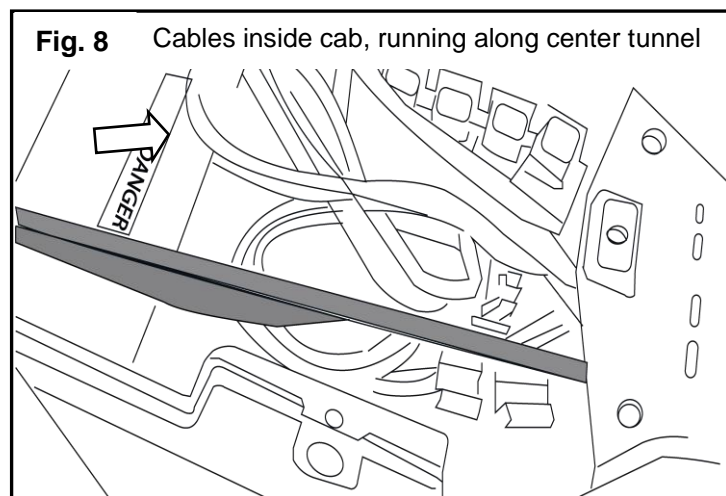
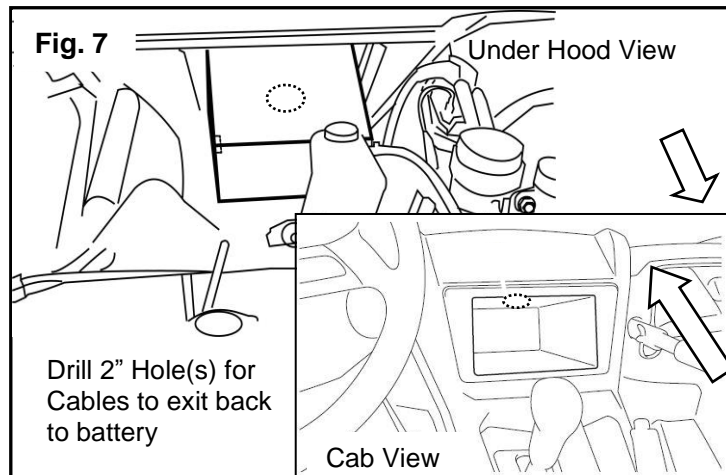
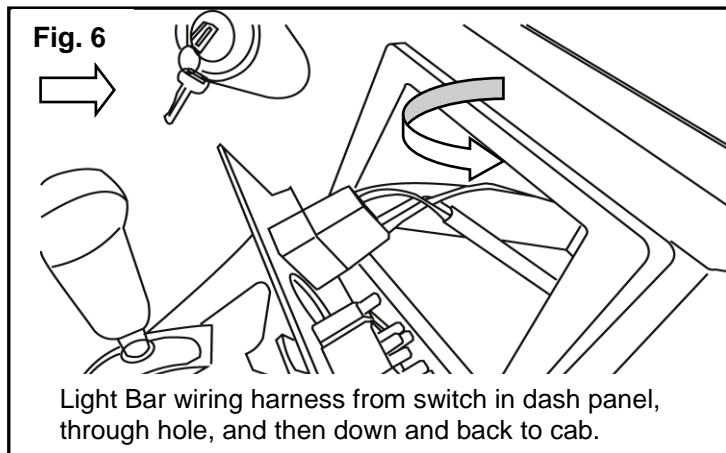
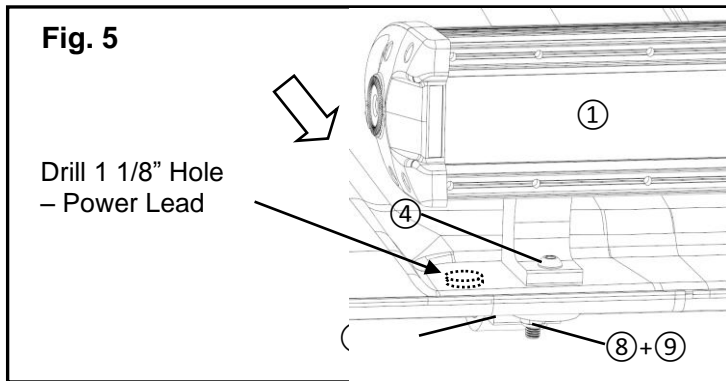

out holes. Working from the top pass an M6x20mm Button Head Bolt (4) through the base of the Roof Mount (3), roof, and thread into the Upper Bracket. Tighten just hand tight. See Fig. 4 & 5.

14. Install a Collar (7) to a T Bolt (6). Ensure the 'T' in the bolt head seats correctly into the Collar.
15. Slide the Collar/T-Bolt assembly into the Light Bar (10) channel. One on each side. Refer to Fig. 3 and Fig. 4.
16. Carefully lower the Light Bar into position on the roof as you pass the threaded ends of the T Bolts (6) through the roof mount bases and the upper brackets (1).
17. Working from inside the cab, install a washer (8) and Flange Nut (9) to both T Bolts (7) and hand tighten.
18. While pushing the upper bracket against the underside of the roof, torque the 8 M6x16mm bolts that attach the lower brackets to the upper brackets to 10 Nm.
19. Adjust the Light Bar position to get access to the 2 M6x20mm button head bolts (4). Torque these bolts to 8 Nm.
20. Slide the light bar off to the side to permit access to drill a 1-1/8" hole for the Power Lead through the roof. (Fig. 5).
21. Pass the power cable from the light bar down through the 1-1/8" hole while installing the grommet into the hole.
22. Center the Light Bar (1) along the leading edge of the roof and adjust to the desired angle. Tighten both M6 Nylock nuts (9). To change the light bar angle, loosen the nuts M6 Nylock nuts (9), adjust the bar and retighten.

Note: You should see about 1/4" of exposed threads from the T-bolt after you've tightened the nut. If not, loosen the M6 Nylock nut and re-seat the T-bolt head in the collar.

Install the Wiring Harness

21. A high level view of the wire route used is shown in Fig. 12. Start by installing the On/Off switch. Yamaha recommends using the Switch Panel Kit (p/n 2HC-H2570-V0). Separate the switch from the plug on the harness, and mount the Light Bar on/off switch by pressing it into one of the 4 rectangular openings in the Switch Panel. If you did not purchase the Switch Panel Kit, you may mount the switch in a location of your choice in the dash area of the vehicle.
22. Refer to the service manual for the procedure to remove the front fender. Working from the front of the vehicle, use a hole saw to cut a 2" hole through the dash box on the top, near the center of the dash box. Slice an opening in the grommet from the Dash Panel Kit to run the cable through and insert the grommet. Route cables through the grommet.

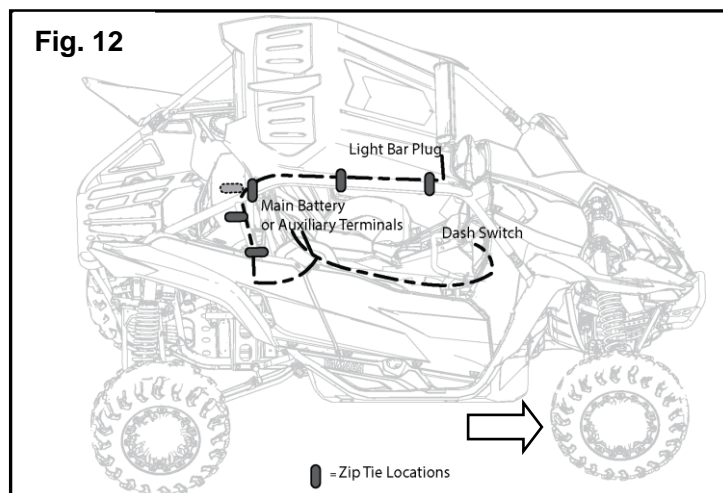
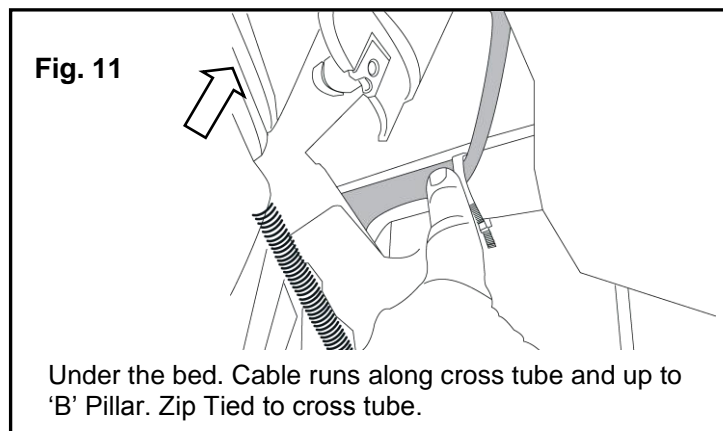
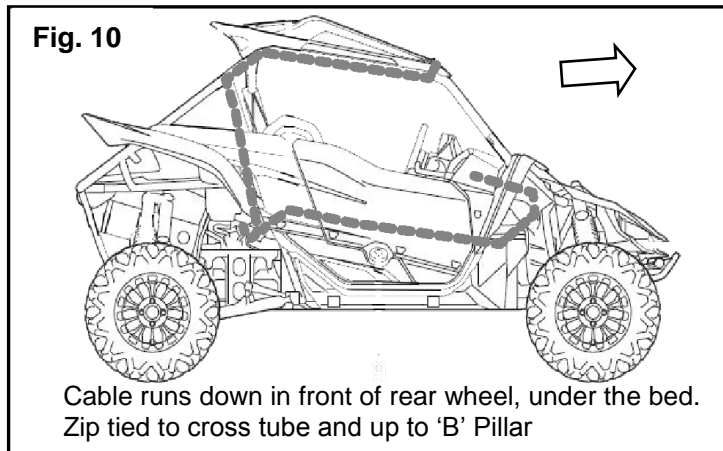
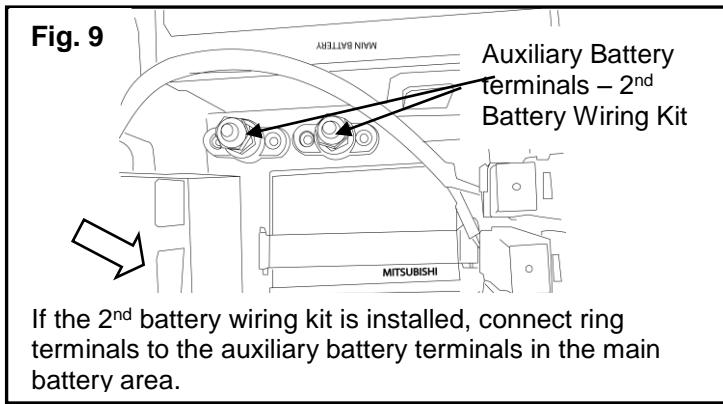

23. Working from the passenger side, remove the console top covers (A and B from the vehicle owner's manual). Retain all parts and hardware for reuse.
24. Working from inside the vehicle, plug the wire harness into the On/Off switch mounted to the Switch Panel. Working from the front of the vehicle, route both cables through the center tunnel on the passenger side.
25. Remove the 5 stock plastic rivets that attach the console side cover. Pull back the console side cover. Run both cables along the console side and back into the main battery box (Fig. 8).
26. If installing a 2nd battery kit, skip to step 27. Connect the ring terminals of the Wiring Harness ⑩ to the main battery. Bundle the remaining battery cable and secure it inside the battery box area. Skip to step 28.

Note: The 2nd battery can be installed with a 2nd battery mount kit or into the 2nd battery location inside the Rear Cargo Box.

27. Do not connect to the main battery. Connect the + (red) and - (black) ring terminals of the Wiring Harness ⑩ to the auxiliary terminal posts + (red) and - (black). *These would have been installed as part of the auxiliary battery wiring kit. Torque battery terminals to no more than 10Nm (7.4 ft-lbf).
28. Route the light bar cable rearward out of the cabin, to the inside of the B Pillar and then upwards towards the roof. Tuck the cable between the roof bars and the roof.
29. Coil excess cable in the battery location or under the front fender. Secure all loose wires using cable ties.
30. Reinstall the remaining body panels. Torque bolts to 5 Nm.

MAINTENANCE:

Periodically, check torque on all hardware. If loose hardware is found, re-torque to specification.

CARE AND CLEANING:

Clean painted metal parts with a clean soft cloth and mild soap and water. Rinse and dry. Clean the windshield with a clean soft cloth and mild soap and water solution.

CUSTOMER SERVICE:

For further information see your Yamaha dealer.

ESTIMATED TIME TO INSTALL: 2.0 HRS